

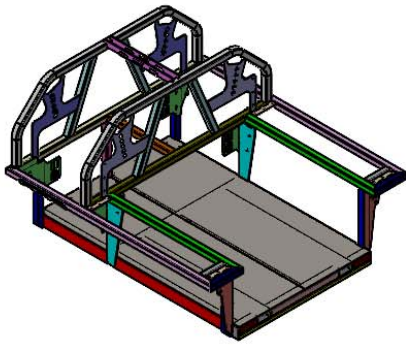

999100

Cut List on next 2 Sheets



UNLESS OTHERWISE SPECIFIED: DIMENSIONS ARE IN INCHES TOLERANCES: ANGULAR: $\pm .05^\circ$ TWO PLACE DECIMAL $\pm .030$ THREE PLACE DECIMAL $\pm .010$ DO NOT SCALE DRAWING		NAME	DATE	 Nemesis Industries, Inc 33990 CR-27 T: 303-974-2440 Kiowa, Co 80117 F: 303-953-5212 www.nem-ind.com
	DRAWN	MRH	9/9/2025	
	APPROVED			
	Drawing Status	Development		
MATERIAL: Steel	COMMENTS:			
THICKNESS:	Exploded & Part Numbers			
FINISH:				
PROPRIETARY AND CONFIDENTIAL				
THE INFORMATION CONTAINED IN THIS DRAWING IS THE SOLE PROPERTY OF NEMESIS INDUSTRIES, INC. ANY REPRODUCTION IN PART OR AS A WHOLE WITHOUT THE WRITTEN PERMISSION OF NEMESIS INDUSTRIES, INC IS PROHIBITED.				

Part Number **99910-91** REV **1**

SHEET 1 OF 19

5

4

3

2

1

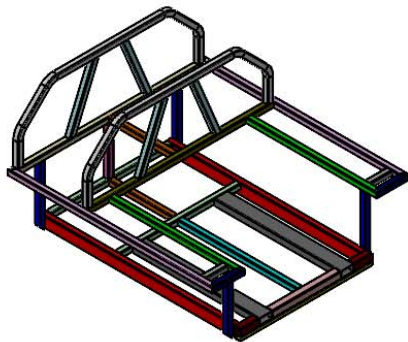
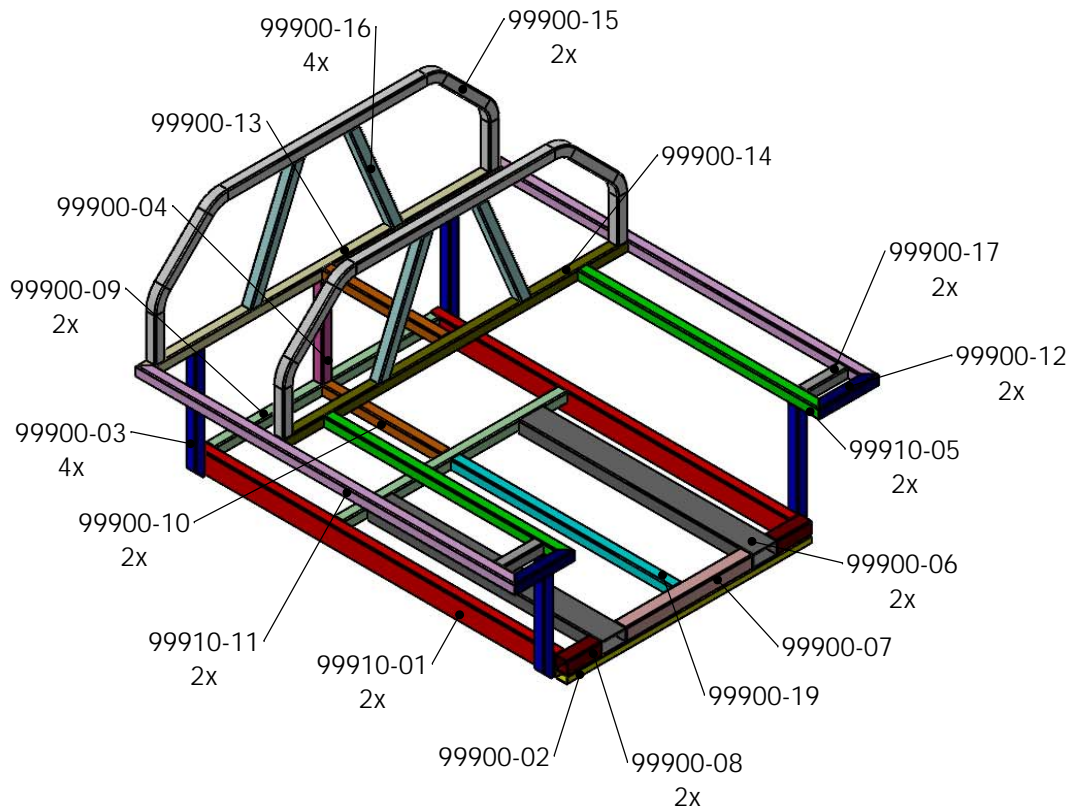

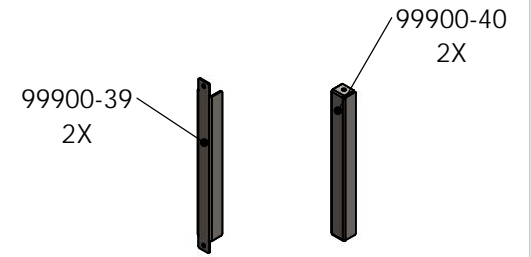
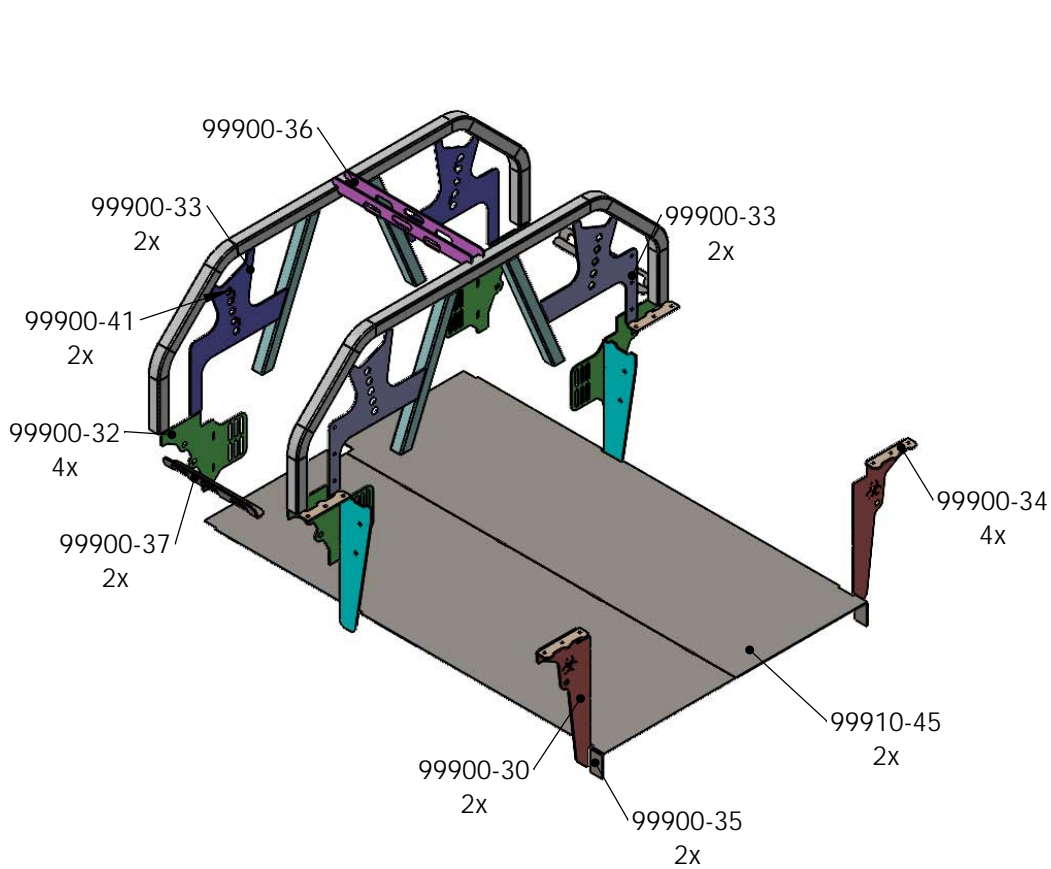

Cut List			
QTY.	PART #	Size	Material
2	99910-01	.125 - 2 x 4	Tube Steel
2	99910-05	.125 - 2 x 2	Tube Steel
2	99910-11	-X	Tube Steel
1	99900-02	.125 - 1.5x2.5	Tube Steel
4	99900-03	.125 - 2x2	Tube Steel
1	99900-04	.125 - 2x2	Tube Steel
2	99900-06	.1875 - 2.5x5	Tube Steel
1	99900-07	.125 - 2.5x2.5	Tube Steel
2	99900-08	.125 - 2.5x2.5	Tube Steel
2	99900-09	.125 - 2x2	Tube Steel
2	99900-10	.125 - 2x2	Tube Steel
2	99900-12	.125 - 2x2	Tube Steel
1	99900-13	.125 - 2x2	Tube Steel
1	99900-14	.125 - 2x2	Tube Steel
2	99900-15	.125 - 2x2	Tube Steel
4	99900-16	.125 - 2x2	Tube Steel
2	99900-17	.125 - 2x2	Tube Steel
1	99900-19	.125 - 2x2	Tube Steel

UNLESS OTHERWISE SPECIFIED: DIMENSIONS ARE IN INCHES TOLERANCES: ANGULAR: ± .05° TWO PLACE DECIMAL ±.030 THREE PLACE DECIMAL ±.010 DO NOT SCALE DRAWING MATERIAL: Steel THICKNESS: FINISH:	DRAWN MRH	NAME MRH	DATE 9/9/2025	 Nemesis Industries, Inc 33990 CR-27 Kiowa, Co 80117 www.nem-ind.com T: 303-974-2440 F: 303-953-5212	
	APPROVED	Drawing Status Development			
	COMMENTS: Tube Material				Part Number 99910-91
					REV 1
SHEET 2 OF 19					
PROPRIETARY AND CONFIDENTIAL THE INFORMATION CONTAINED IN THIS DRAWING IS THE SOLE PROPERTY OF NEMESIS INDUSTRIES, INC. ANY REPRODUCTION IN PART OR AS A WHOLE WITHOUT THE WRITTEN PERMISSION OF NEMESIS INDUSTRIES, INC IS PROHIBITED.					

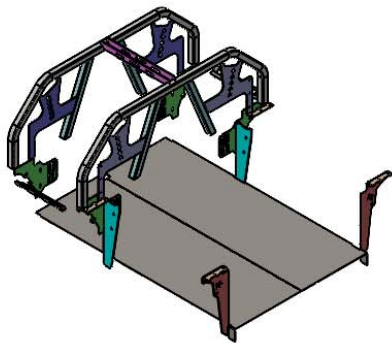

Cut List				
QTY.	PART #	Flat #	Thick	Material
2	99910-38	-38	.1875	ASTM A36 Steel
2	99910-45	-45	.125	ASTM A36 Steel
2	99900-30	-30	.1875	ASTM A36 Steel
4	99900-32	-32	.1875	ASTM A36 Steel
2	99900-33	-33	.1875	ASTM A36 Steel
4	99900-34	-34	.1875	ASTM A36 Steel
2	99900-35	-35	.1875	ASTM A36 Steel
1	99900-36	-X36	.1875	ASTM A36 Steel
2	99900-37	-X37	.1875	ASTM A36 Steel
2	99900-39	-X39	0.188	ASTM A36 Steel
2	99900-40	-X40	0.188	ASTM A36 Steel
2	99900-41	-41	.1875	ASTM A36 Steel
2	99900-43	-33	.1875	ASTM A36 Steel
2	99900-15	.125 - 2x2		Tube Steel
4	99900-16	.125 - 2x2		Tube Steel



UNLESS OTHERWISE SPECIFIED:	NAME	DATE	 Nemesis Industries, Inc 33990 CR-27 T: 303-974-2440 Kiowa, Co 80117 F: 303-953-5212 www.nem-ind.com	
DIMENSIONS ARE IN INCHES	DRAWN	MRH 9/9/2025		
TOLERANCES:	APPROVED			
ANGULAR: ± .05°	Drawing Status	Development		
TWO PLACE DECIMAL ±.030	COMMENTS:	Sheet Material	Part Number	REV
THREE PLACE DECIMAL ±.010			99910-91	1
DO NOT SCALE DRAWING			SHEET 3 OF 19	
MATERIAL:	PROPRIETARY AND CONFIDENTIAL			
Steel	THE INFORMATION CONTAINED IN THIS DRAWING IS THE SOLE PROPERTY OF NEMESIS INDUSTRIES, INC. ANY REPRODUCTION IN PART OR AS A WHOLE WITHOUT THE WRITTEN PERMISSION OF NEMESIS INDUSTRIES, INC IS PROHIBITED.			
THICKNESS:				
FINISH:				

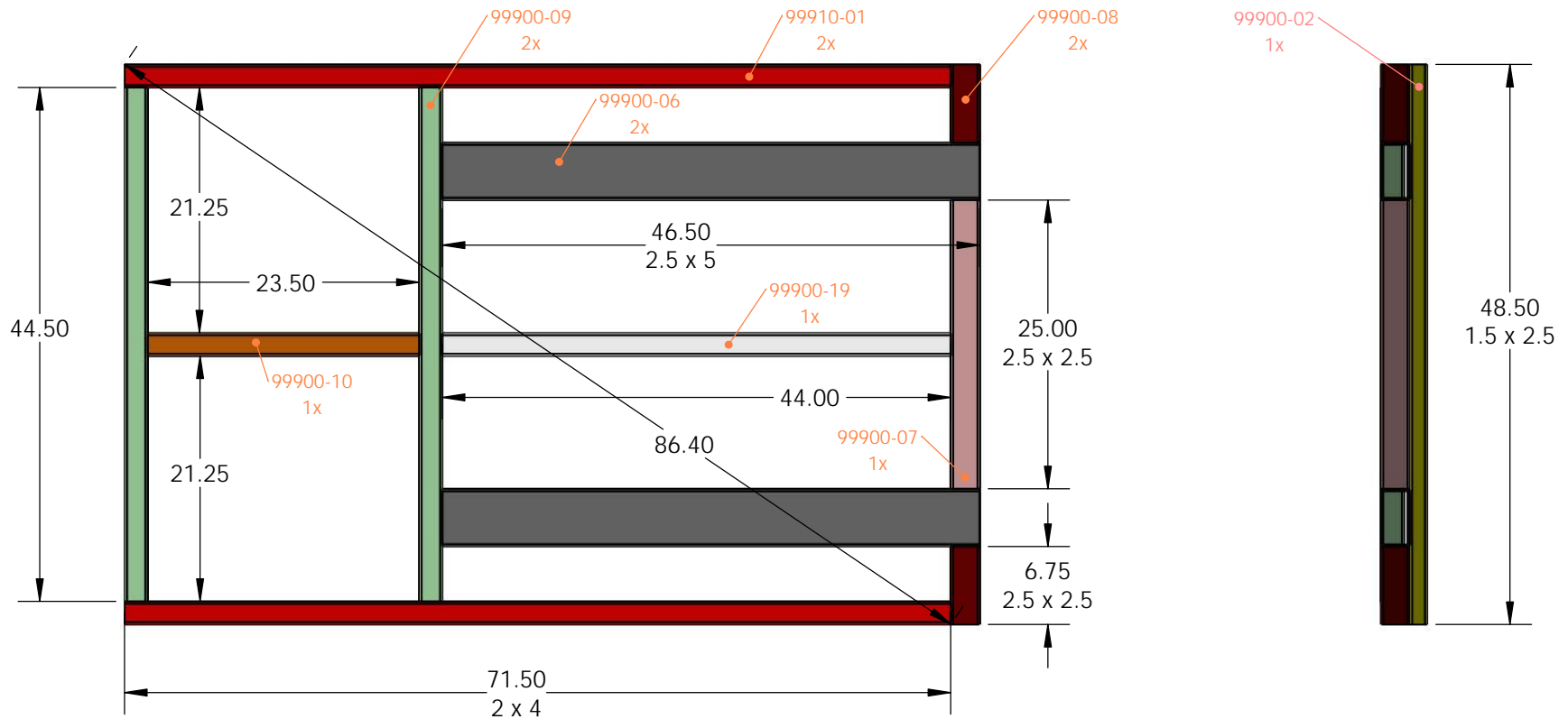

Part is 2 x 2 unless noted

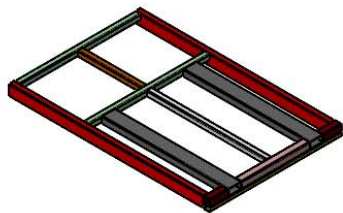

UNLESS OTHERWISE SPECIFIED: DIMENSIONS ARE IN INCHES TOLERANCES: ANGULAR: $\pm .05^\circ$ TWO PLACE DECIMAL $\pm .030$ THREE PLACE DECIMAL $\pm .010$ DO NOT SCALE DRAWING MATERIAL: Steel THICKNESS: FINISH:	DRAWN MRH	NAME MRH	DATE 9/9/2025	
	APPROVED	Drawing Status Development		
	COMMENTS: Tubes - Base			33990 CR-27 Kiowa, Co 80117 www.nem-ind.com
				T: 303-974-2440 F: 303-953-5212
		Part Number 99910-91	REV 1	
SHEET 4 OF 19				
PROPRIETARY AND CONFIDENTIAL THE INFORMATION CONTAINED IN THIS DRAWING IS THE SOLE PROPERTY OF NEMESIS INDUSTRIES, INC. ANY REPRODUCTION IN PART OR AS A WHOLE WITHOUT THE WRITTEN PERMISSION OF NEMESIS INDUSTRIES, INC IS PROHIBITED.				

Template "Location" will read correctly when the template is in the correct position.

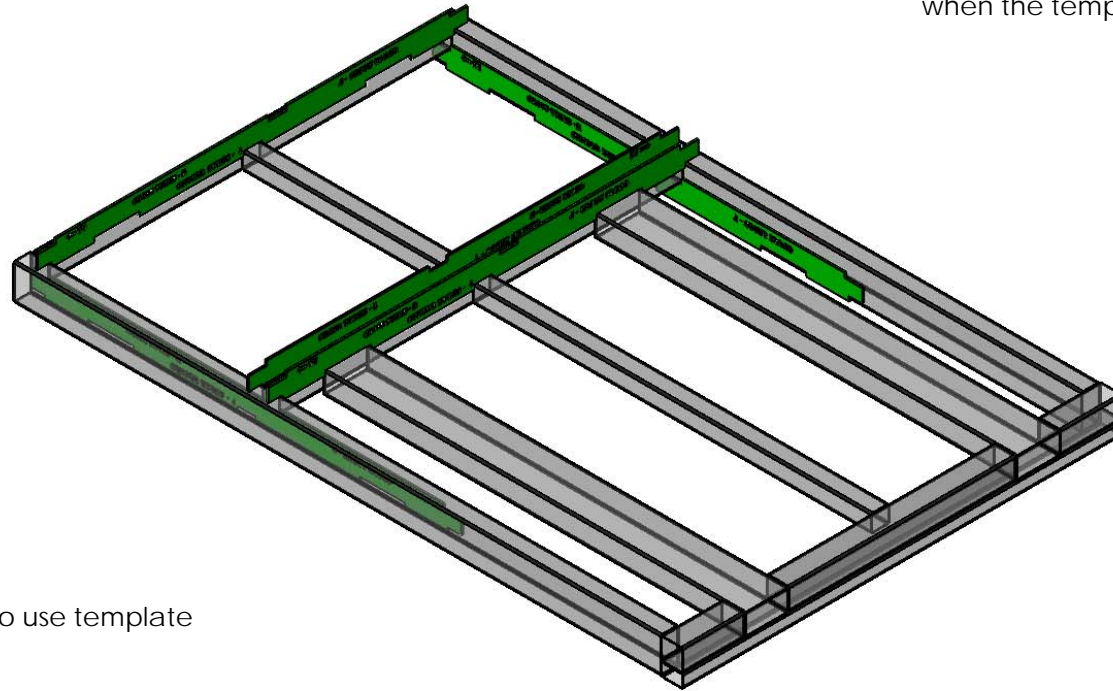

Samples of where to use template

Check Weld Details Page
for Assembly / Welding Notes

Everything is 2 x 2 unless noted

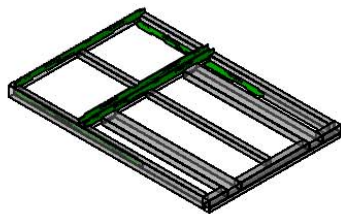

UNLESS OTHERWISE SPECIFIED:	NAME	DATE	 Nemesis Industries, Inc 33990 CR-27 T: 303-974-2440 Kiowa, Co 80117 F: 303-953-5212 www.nem-ind.com	
DIMENSIONS ARE IN INCHES	DRAWN	MRH 9/9/2025		
TOLERANCES:	APPROVED			
ANGULAR: $\pm .05^\circ$	Drawing Status	Development		
TWO PLACE DECIMAL $\pm .030$	COMMENTS:	Templates - Tubes Base	Part Number	REV
THREE PLACE DECIMAL $\pm .010$			99910-91	1
DO NOT SCALE DRAWING			SHEET 5 OF 19	
MATERIAL:	PROPRIETARY AND CONFIDENTIAL			
Steel	THE INFORMATION CONTAINED IN THIS DRAWING IS THE SOLE PROPERTY OF NEMESIS INDUSTRIES, INC. ANY REPRODUCTION IN PART OR AS A WHOLE WITHOUT THE WRITTEN PERMISSION OF NEMESIS INDUSTRIES, INC IS PROHIBITED.			
THICKNESS:				
FINISH:				

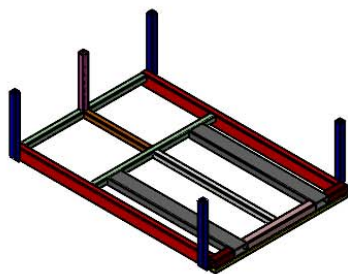
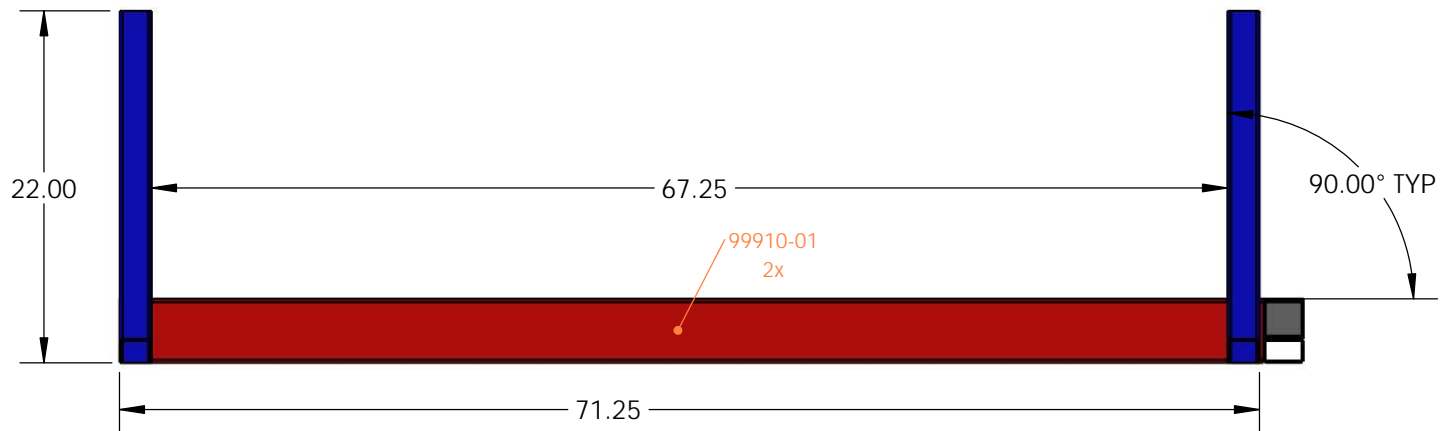
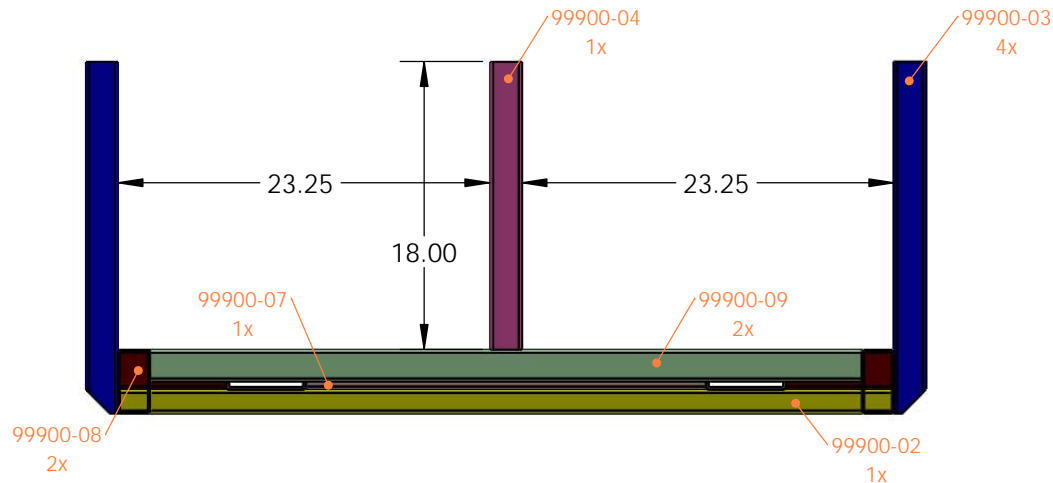

UNLESS OTHERWISE SPECIFIED: DIMENSIONS ARE IN INCHES TOLERANCES: ANGULAR: ± .05° TWO PLACE DECIMAL ± .030 THREE PLACE DECIMAL ± .010	NAME	DATE	 Nemesis Industries, Inc 33990 CR-27 T: 303-974-2440 Kiowa, Co 80117 F: 303-953-5212 www.nem-ind.com	
	DRAWN	MRH 9/9/2025		
	APPROVED			
	Drawing Status	Development		
DO NOT SCALE DRAWING	COMMENTS:		Part Number	REV
MATERIAL: Steel	Tubes - Uprights		99910-91	1
THICKNESS:			SHEET 6 OF 19	
FINISH:				
PROPRIETARY AND CONFIDENTIAL THE INFORMATION CONTAINED IN THIS DRAWING IS THE SOLE PROPERTY OF NEMESIS INDUSTRIES, INC. ANY REPRODUCTION IN PART OR AS A WHOLE WITHOUT THE WRITTEN PERMISSION OF NEMESIS INDUSTRIES, INC IS PROHIBITED.				

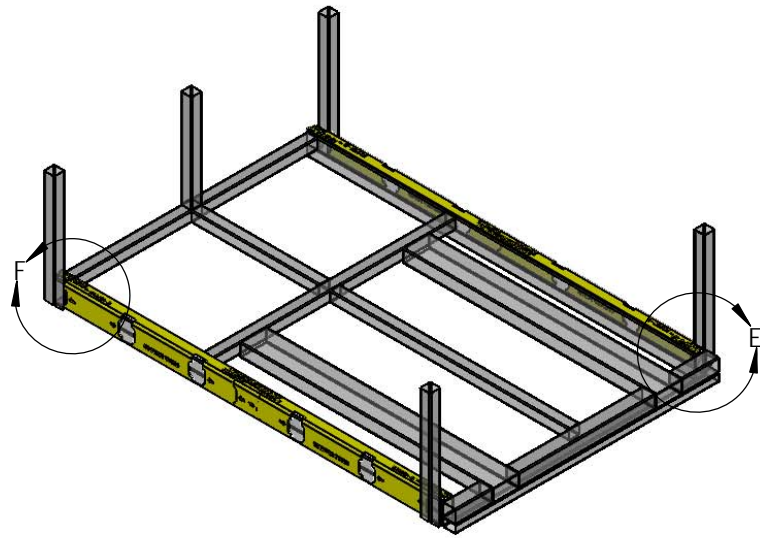

Samples of where to use template

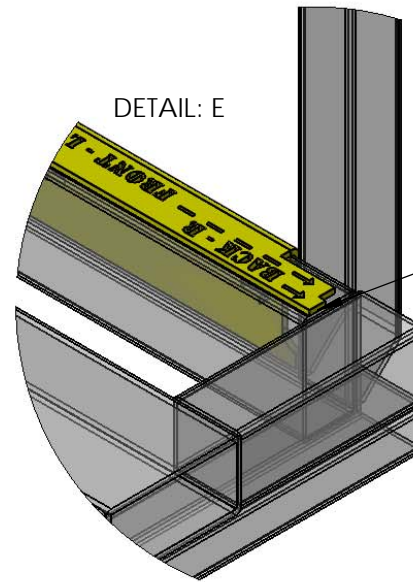

Use this Tab for Rear alignment

Use this indent for Front alignment

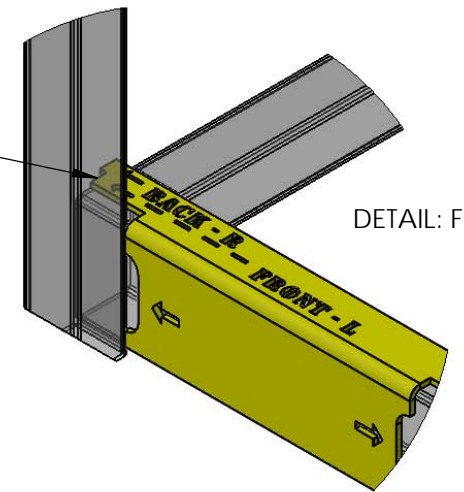

DETAIL: F

Template "Location" will read correctly when the template is in the correct position.

Check Weld Details Page for Assembly / Welding Notes

Everything is 2 x 2 unless noted

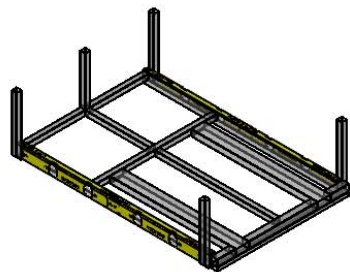

UNLESS OTHERWISE SPECIFIED:		NAME	DATE
DIMENSIONS ARE IN INCHES		DRAWN	MRH 9/9/2025
TOLERANCES:		APPROVED	
ANGULAR: $\pm .05^\circ$		Drawing Status	Development
TWO PLACE DECIMAL $\pm .030$		COMMENTS:	
THREE PLACE DECIMAL $\pm .010$			
DO NOT SCALE DRAWING		Templates - Tubes Uprights	
MATERIAL: Steel		Part Number 99910-91	
THICKNESS:		www.nem-ind.com	
FINISH:		33990 CR-27 Kiowa, Co 80117 T: 303-974-2440 F: 303-953-5212	
		REV 1	
SHEET 7 OF 19			



Nemesis Industries, Inc

33990 CR-27
Kiowa, Co 80117
www.nem-ind.com
T: 303-974-2440
F: 303-953-5212

PROPRIETARY AND CONFIDENTIAL

THE INFORMATION CONTAINED IN THIS DRAWING IS THE SOLE PROPERTY OF NEMESIS INDUSTRIES, INC. ANY REPRODUCTION IN PART OR AS A WHOLE WITHOUT THE WRITTEN PERMISSION OF NEMESIS INDUSTRIES, INC IS PROHIBITED.

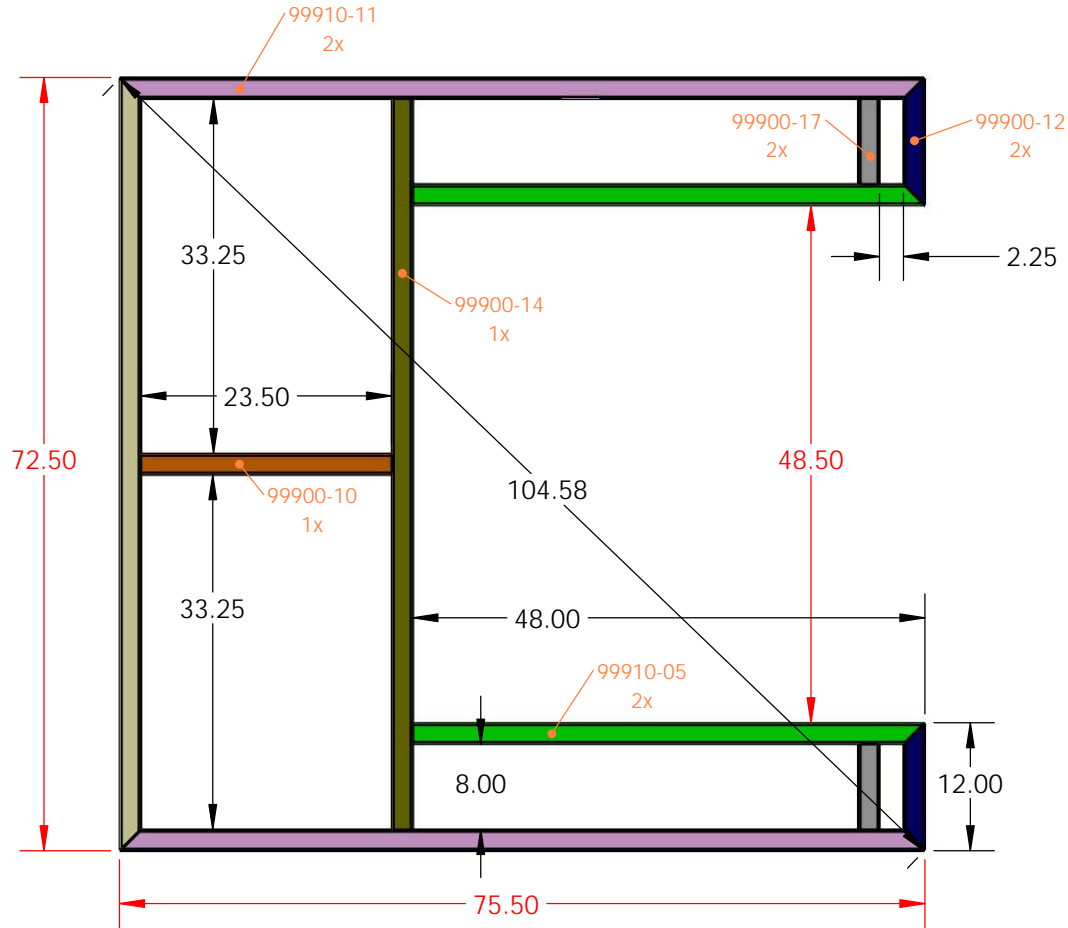

Check Weld Details Page
for Assembly / Welding Notes

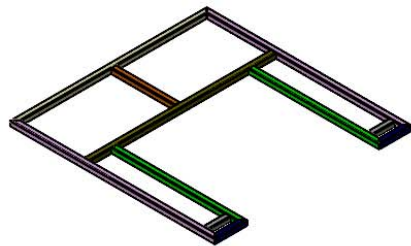

UNLESS OTHERWISE SPECIFIED:		NAME	DATE
DIMENSIONS ARE IN INCHES		DRAWN	MRH 9/9/2025
TOLERANCES:		APPROVED	
ANGULAR: $\pm .05^\circ$		Drawing Status	Development
TWO PLACE DECIMAL $\pm .030$		COMMENTS:	
THREE PLACE DECIMAL $\pm .010$			
DO NOT SCALE DRAWING			
MATERIAL:		Tubes - Mid1	
Steel			
THICKNESS:			
FINISH:			
		 Nemesis Industries, Inc 33990 CR-27 T: 303-974-2440 Kiowa, Co 80117 F: 303-953-5212 www.nem-ind.com	
		Part Number	REV
		99910-91	1
SHEET 8 OF 19			
PROPRIETARY AND CONFIDENTIAL THE INFORMATION CONTAINED IN THIS DRAWING IS THE SOLE PROPERTY OF NEMESIS INDUSTRIES, INC. ANY REPRODUCTION IN PART OR AS A WHOLE WITHOUT THE WRITTEN PERMISSION OF NEMESIS INDUSTRIES, INC IS PROHIBITED.			

Template "Location" will read correctly when the template is in the correct position.

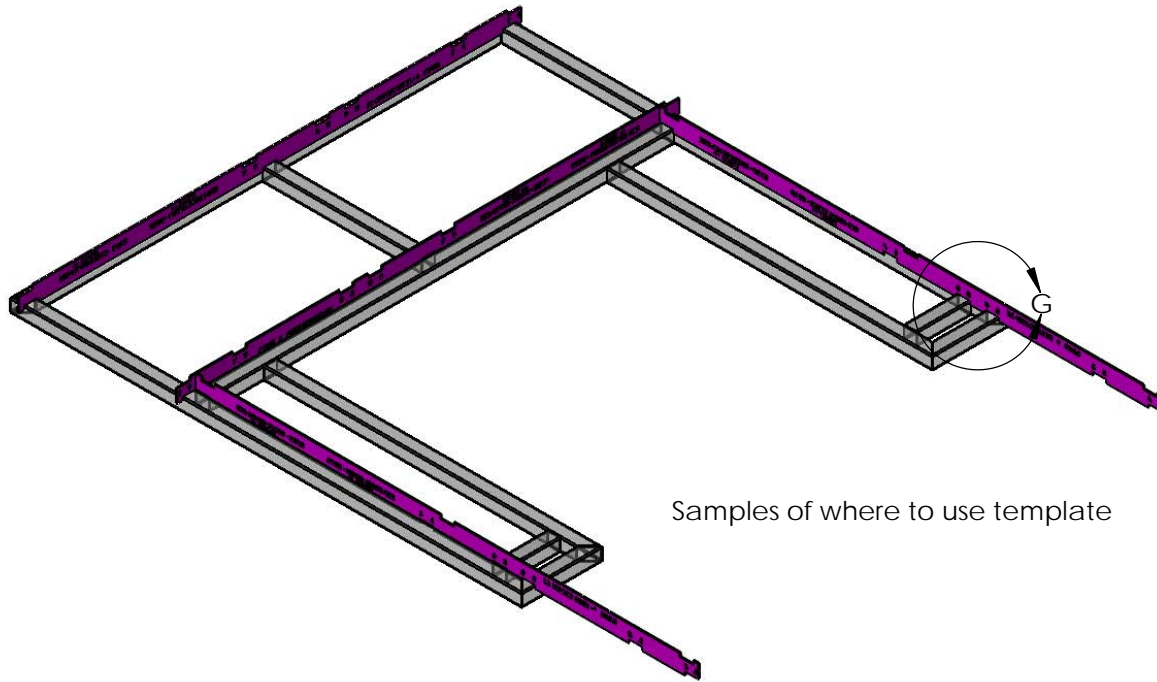

Samples of where to use template

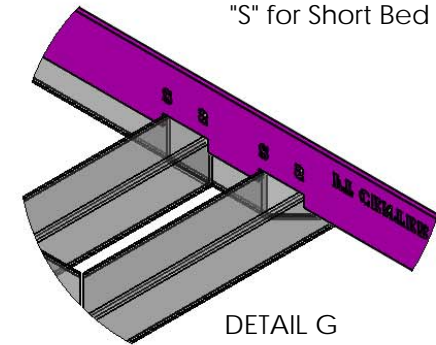

"S" for Short Bed Locations

DETAIL G

Check Weld Details Page
for Assembly / Welding Notes

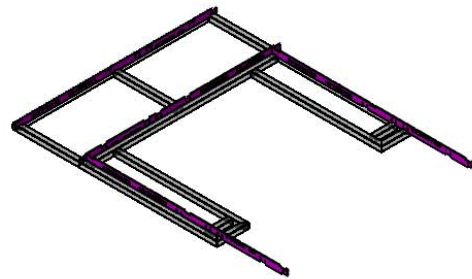

UNLESS OTHERWISE SPECIFIED:	NAME	DATE	 Nemesis Industries, Inc 33990 CR-27 T: 303-974-2440 Kiowa, Co 80117 F: 303-953-5212 www.nem-ind.com	
DIMENSIONS ARE IN INCHES	DRAWN	MRH 9/9/2025		
TOLERANCES:	APPROVED			
ANGULAR: $\pm .05^\circ$	Drawing Status	Development		
TWO PLACE DECIMAL $\pm .030$	COMMENTS:	Templates - Tubs Mid	Part Number	REV
THREE PLACE DECIMAL $\pm .010$			99910-91	1
DO NOT SCALE DRAWING			SHEET 9 OF 19	
MATERIAL: Steel	PROPRIETARY AND CONFIDENTIAL			
THICKNESS:	THE INFORMATION CONTAINED IN THIS DRAWING IS THE SOLE PROPERTY OF NEMESIS INDUSTRIES, INC. ANY REPRODUCTION IN PART OR AS A WHOLE WITHOUT THE WRITTEN PERMISSION OF NEMESIS INDUSTRIES, INC IS PROHIBITED.			
FINISH:				

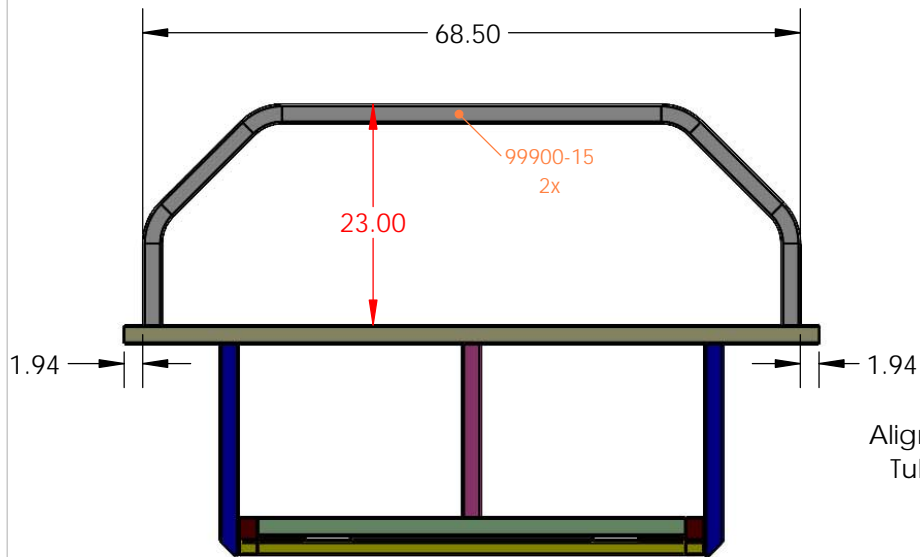

Align Hoop with
Tube it sits on

2 Hoops are Identical

Align Hoop with
Tube it sits on

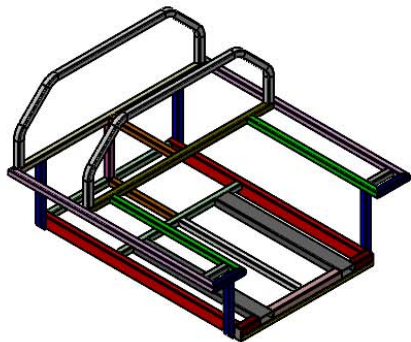
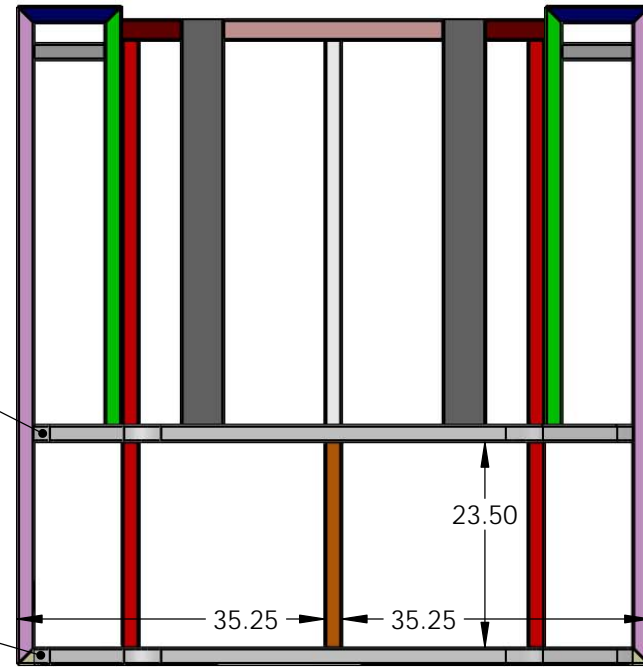

Check Weld Details Page
for Assembly / Welding Notes

Everything is 2 x 2 unless noted

UNLESS OTHERWISE SPECIFIED:		NAME	DATE	 Nemesis Industries, Inc 33990 CR-27 T: 303-974-2440 Kiowa, Co 80117 F: 303-953-5212 www.nem-ind.com	
DIMENSIONS ARE IN INCHES		DRAWN	MRH 9/9/2025		
TOLERANCES:		APPROVED			
ANGULAR: ± .05°		Drawing Status	Development		
TWO PLACE DECIMAL ±.030		COMMENTS:		Part Number	
THREE PLACE DECIMAL ±.010		Tubes - Hoops		99910-91	
DO NOT SCALE DRAWING				REV	
MATERIAL:				1	
Steel		SHEET 11 OF 19			
THICKNESS:					
FINISH:					
PROPRIETARY AND CONFIDENTIAL THE INFORMATION CONTAINED IN THIS DRAWING IS THE SOLE PROPERTY OF NEMESIS INDUSTRIES, INC. ANY REPRODUCTION IN PART OR AS A WHOLE WITHOUT THE WRITTEN PERMISSION OF NEMESIS INDUSTRIES, INC IS PROHIBITED.					

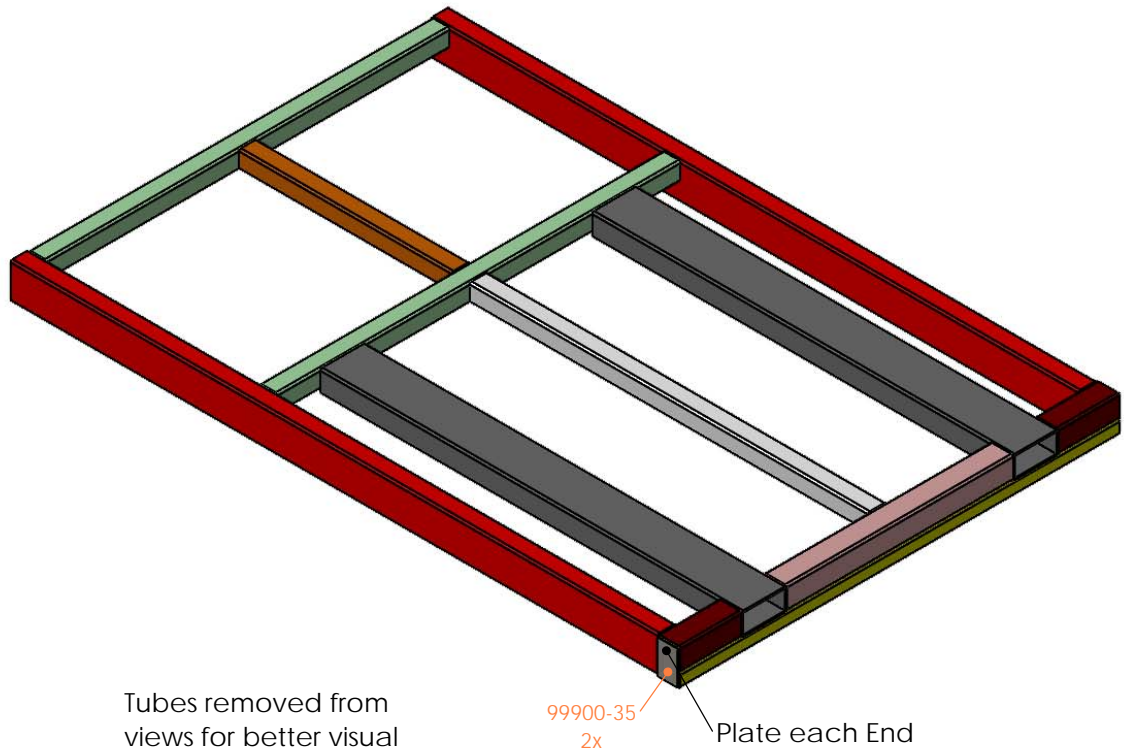

Tubes removed from views for better visual

Check Weld Details Page
for Assembly / Welding Notes

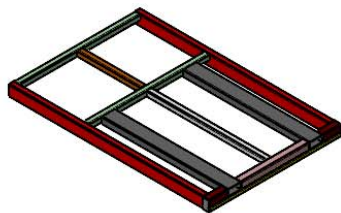

UNLESS OTHERWISE SPECIFIED:	NAME	DATE	 Nemesis Industries, Inc 33990 CR-27 T: 303-974-2440 Kiowa, Co 80117 F: 303-953-5212 www.nem-ind.com	
DIMENSIONS ARE IN INCHES	DRAWN	MRH 9/9/2025		
TOLERANCES:	APPROVED			
ANGULAR: $\pm .05^\circ$	Drawing Status	Development		
TWO PLACE DECIMAL $\pm .030$	COMMENTS:		Part Number	REV
THREE PLACE DECIMAL $\pm .010$			99910-91	1
DO NOT SCALE DRAWING			SHEET 12 OF 19	
MATERIAL:			<p align="center">PROPRIETARY AND CONFIDENTIAL</p> <p align="center">THE INFORMATION CONTAINED IN THIS DRAWING IS THE SOLE PROPERTY OF NEMESIS INDUSTRIES, INC. ANY REPRODUCTION IN PART OR AS A WHOLE WITHOUT THE WRITTEN PERMISSION OF NEMESIS INDUSTRIES, INC IS PROHIBITED.</p>	
Steel				
THICKNESS:				
FINISH:				

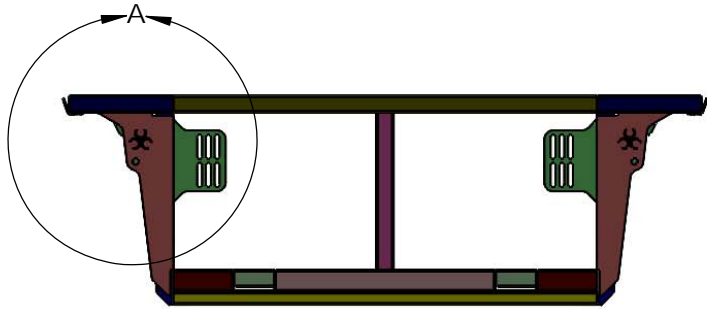
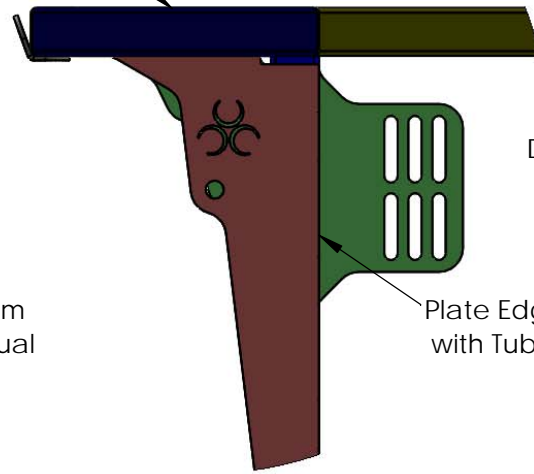

Plate Edge lines
with Tube Face



DETAIL: A

Tubes removed from
views for better visual

Plate Edge lines
with Tube Face

Plate Edge lines with Tube Face

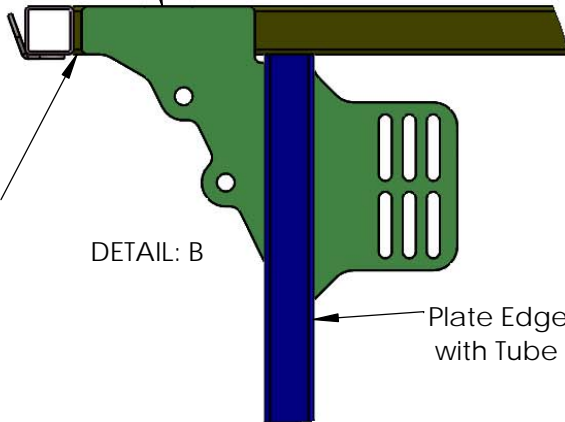

Typical Gap for Tube Welds

DETAIL: B

Plate Edge lines
with Tube Face

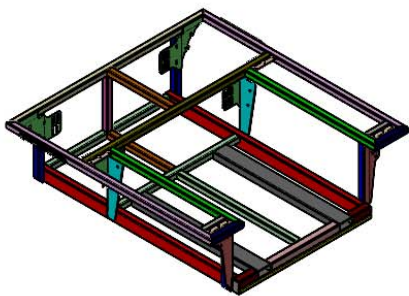
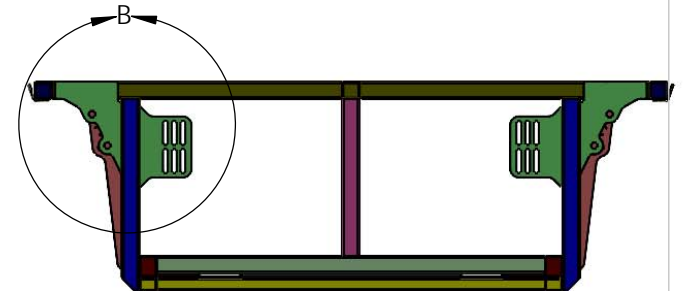

Check Weld Details Page
for Assembly / Welding Notes

Everything is 2 x 2 unless noted

UNLESS OTHERWISE SPECIFIED:	NAME	DATE	 Nemesis Industries, Inc 33990 CR-27 T: 303-974-2440 Kiowa, Co 80117 F: 303-953-5212 www.nem-ind.com	
DIMENSIONS ARE IN INCHES	DRAWN	MRH 9/9/2025		
TOLERANCES:	APPROVED			
ANGULAR: $\pm .05^\circ$	Drawing Status	Development		
TWO PLACE DECIMAL $\pm .030$	COMMENTS:	Plates - Mid1	Part Number	REV
THREE PLACE DECIMAL $\pm .010$			99910-91	1
DO NOT SCALE DRAWING			SHEET 13 OF 19	
MATERIAL:				
Steel				
THICKNESS:				
FINISH:				

PROPRIETARY AND CONFIDENTIAL
 THE INFORMATION CONTAINED IN THIS DRAWING IS THE SOLE PROPERTY OF NEMESIS INDUSTRIES, INC. ANY REPRODUCTION IN PART OR AS A WHOLE WITHOUT THE WRITTEN PERMISSION OF NEMESIS INDUSTRIES, INC IS PROHIBITED.

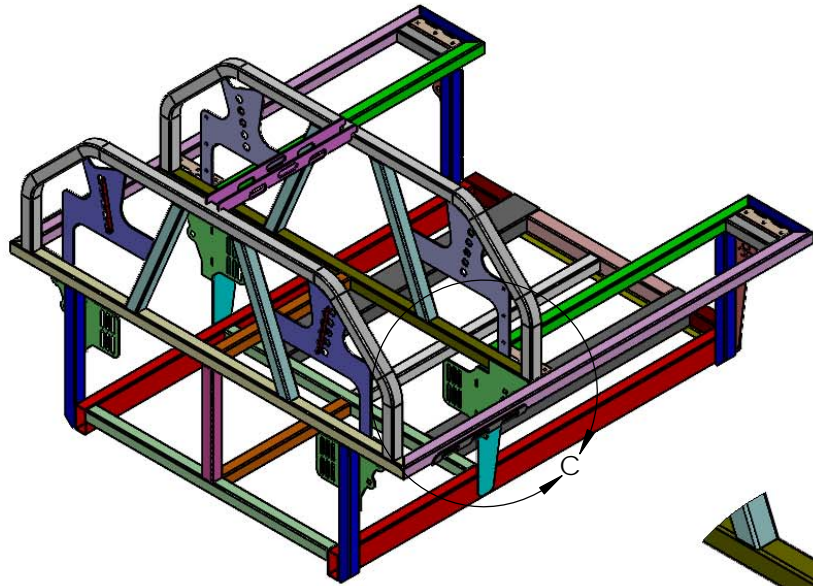

Bottom M&Ts Completely

DETAIL: C

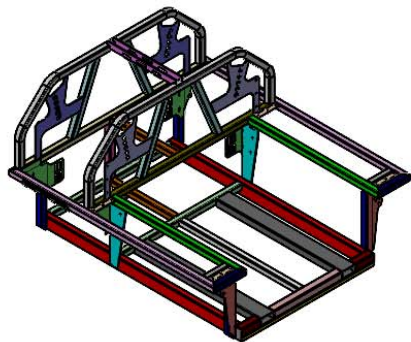
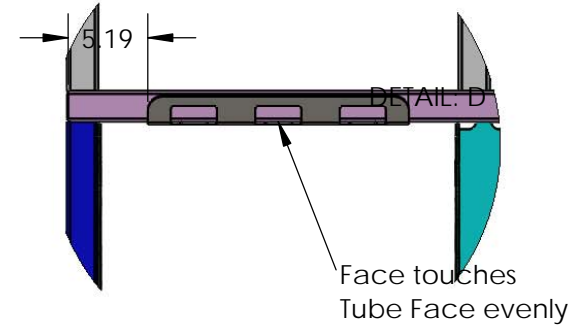
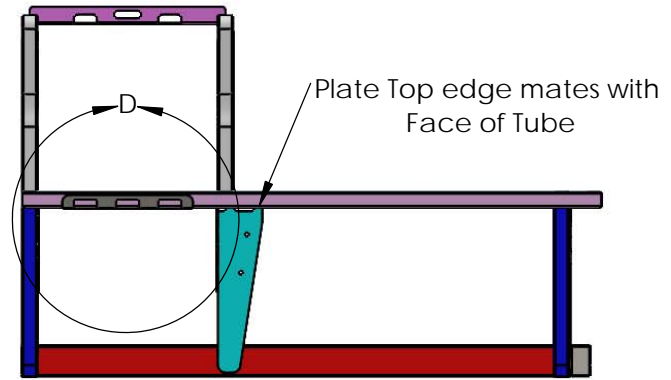

Check Weld Details Page
for Assembly / Welding Notes

Everything is 2 x 2 unless noted

UNLESS OTHERWISE SPECIFIED:	NAME	DATE	 Nemesis Industries, Inc 33990 CR-27 T: 303-974-2440 Kiowa, Co 80117 F: 303-953-5212 www.nem-ind.com	
DIMENSIONS ARE IN INCHES	DRAWN	MRH 9/9/2025		
TOLERANCES:	APPROVED			
ANGULAR: $\pm .05^\circ$	Drawing Status	Development		
TWO PLACE DECIMAL $\pm .030$	COMMENTS:	Plates - Mid2	Part Number	REV
THREE PLACE DECIMAL $\pm .010$			99910-91	1
DO NOT SCALE DRAWING			SHEET 14 OF 19	
MATERIAL:	<p style="text-align: center;">PROPRIETARY AND CONFIDENTIAL</p> <p style="text-align: center;">THE INFORMATION CONTAINED IN THIS DRAWING IS THE SOLE PROPERTY OF NEMESIS INDUSTRIES, INC. ANY REPRODUCTION IN PART OR AS A WHOLE WITHOUT THE WRITTEN PERMISSION OF NEMESIS INDUSTRIES, INC IS PROHIBITED.</p>			
Steel				
THICKNESS:				
FINISH:				

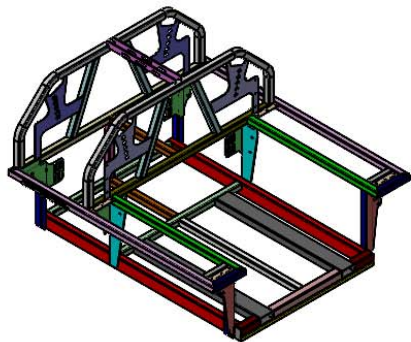
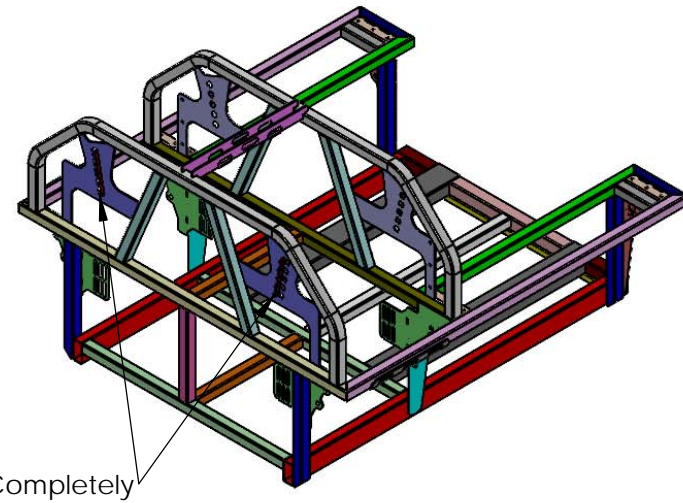
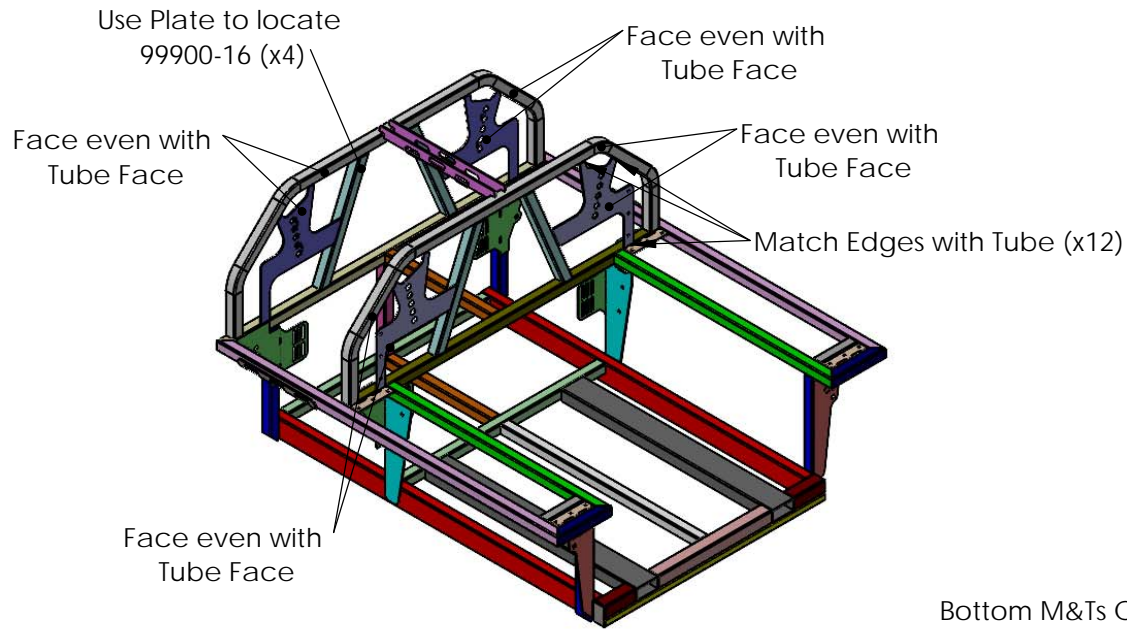

Check Weld Details Page
for Assembly / Welding Notes

Everything is 2 x 2 unless noted

UNLESS OTHERWISE SPECIFIED: DIMENSIONS ARE IN INCHES TOLERANCES: ANGULAR: $\pm .05^\circ$ TWO PLACE DECIMAL $\pm .030$ THREE PLACE DECIMAL $\pm .010$ DO NOT SCALE DRAWING MATERIAL: Steel THICKNESS: FINISH:	NAME	DATE	 Nemesis Industries, Inc 33990 CR-27 Kiowa, Co 80117 www.nem-ind.com T: 303-974-2440 F: 303-953-5212	
	DRAWN	MRH 9/9/2025		
	APPROVED			
	Drawing Status	Development		
COMMENTS:	Plates - Hoops		Part Number	REV
			99910-91	1
			SHEET 15 OF 19	
PROPRIETARY AND CONFIDENTIAL THE INFORMATION CONTAINED IN THIS DRAWING IS THE SOLE PROPERTY OF NEMESIS INDUSTRIES, INC. ANY REPRODUCTION IN PART OR AS A WHOLE WITHOUT THE WRITTEN PERMISSION OF NEMESIS INDUSTRIES, INC IS PROHIBITED.				

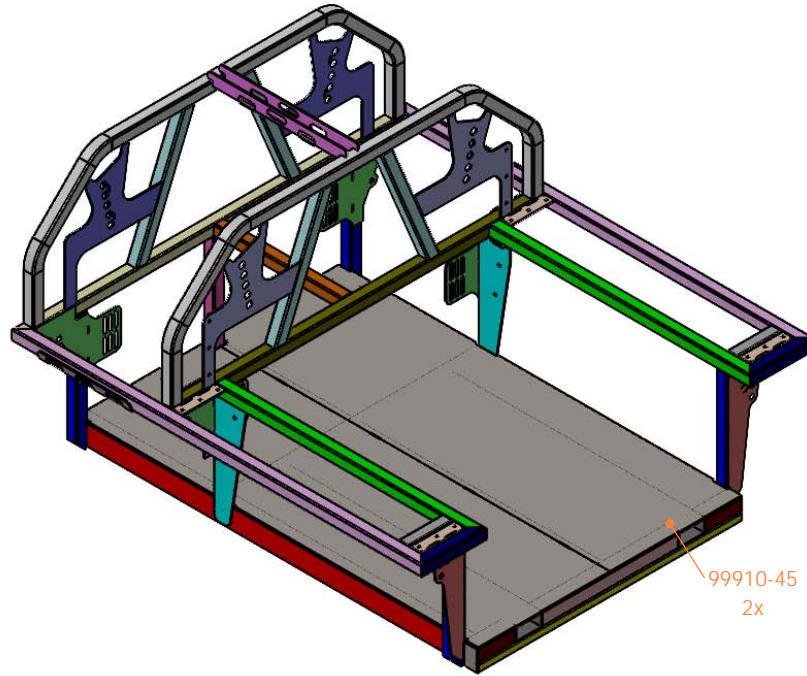

Floor Plate Edges
Line up to Tube Faces

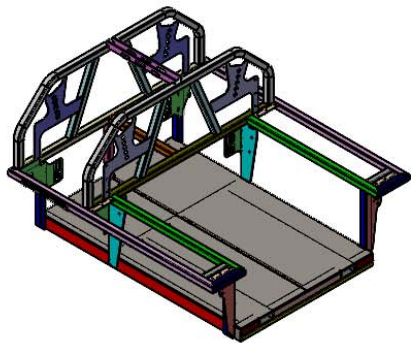

Check Weld Details Page
for Assembly / Welding Notes

Everything is 2 x 2 unless noted

UNLESS OTHERWISE SPECIFIED:	NAME	DATE	 Nemesis Industries, Inc 33990 CR-27 T: 303-974-2440 Kiowa, Co 80117 F: 303-953-5212 www.nem-ind.com	
DIMENSIONS ARE IN INCHES	DRAWN	MRH 9/9/2025		
TOLERANCES:	APPROVED			
ANGULAR: $\pm .05^\circ$	Drawing Status	Development		
TWO PLACE DECIMAL $\pm .030$	COMMENTS:	Plates - Floor	Part Number	REV
THREE PLACE DECIMAL $\pm .010$			99910-91	1
DO NOT SCALE DRAWING			SHEET 16 OF 19	
MATERIAL:	PROPRIETARY AND CONFIDENTIAL			
Steel	THE INFORMATION CONTAINED IN THIS DRAWING IS THE SOLE PROPERTY OF NEMESIS INDUSTRIES, INC. ANY REPRODUCTION IN PART OR AS A WHOLE WITHOUT THE WRITTEN PERMISSION OF NEMESIS INDUSTRIES, INC IS PROHIBITED.			
THICKNESS:				
FINISH:				

Welding Notes:

Need Weld Details

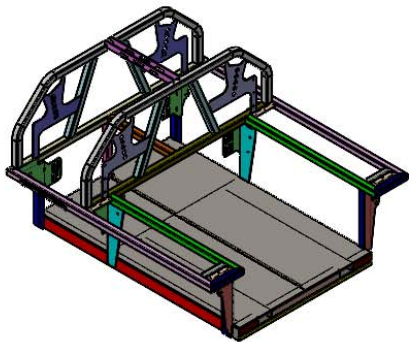

UNLESS OTHERWISE SPECIFIED:		NAME	DATE	 Nemesis Industries, Inc 33990 CR-27 T: 303-974-2440 Kiowa, Co 80117 F: 303-953-5212 www.nem-ind.com	
DIMENSIONS ARE IN INCHES	DRAWN	MRH	9/9/2025		
TOLERANCES: ANGULAR: ± .05°	APPROVED				
TWO PLACE DECIMAL ±.030 THREE PLACE DECIMAL ±.010	Drawing Status	Development			
DO NOT SCALE DRAWING	COMMENTS:			Part Number	
MATERIAL: Steel	Weld Details			99910-91	
THICKNESS:				REV	
FINISH:				1	
				SHEET 17 OF 19	
PROPRIETARY AND CONFIDENTIAL THE INFORMATION CONTAINED IN THIS DRAWING IS THE SOLE PROPERTY OF NEMESIS INDUSTRIES, INC. ANY REPRODUCTION IN PART OR AS A WHOLE WITHOUT THE WRITTEN PERMISSION OF NEMESIS INDUSTRIES, INC IS PROHIBITED.					

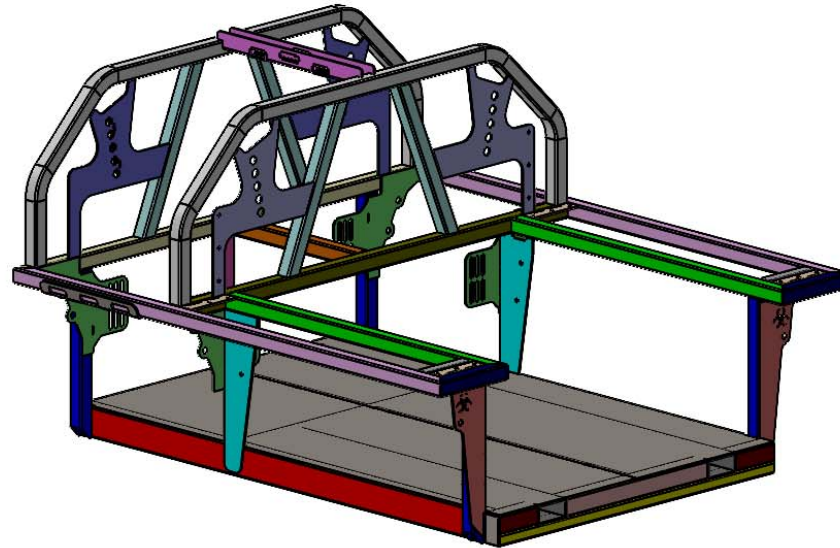

Leave ALL Welds

Zip Disc ALL Edges

Remove any Tooling Marks and Weld Spatter on Sanded Parts only

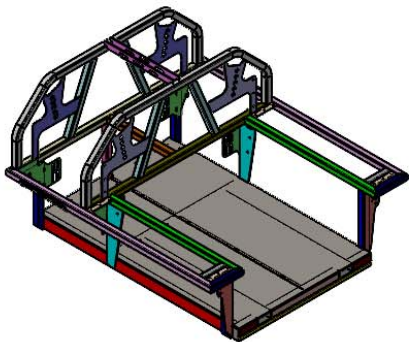

UNLESS OTHERWISE SPECIFIED:	NAME	DATE	 Nemesis Industries, Inc 33990 CR-27 T: 303-974-2440 Kiowa, Co 80117 F: 303-953-5212 www.nem-ind.com	
DIMENSIONS ARE IN INCHES	DRAWN	MRH 9/9/2025		
TOLERANCES:	APPROVED		Drawing Status Development COMMENTS:	
ANGULAR: $\pm .05^\circ$				
TWO PLACE DECIMAL $\pm .030$			Part Number 99910-91	
THREE PLACE DECIMAL $\pm .010$				
DO NOT SCALE DRAWING			REV 1	
MATERIAL: Steel				
THICKNESS:			SHEET 18 OF 19	
FINISH: Finish				
PROPRIETARY AND CONFIDENTIAL THE INFORMATION CONTAINED IN THIS DRAWING IS THE SOLE PROPERTY OF NEMESIS INDUSTRIES, INC. ANY REPRODUCTION IN PART OR AS A WHOLE WITHOUT THE WRITTEN PERMISSION OF NEMESIS INDUSTRIES, INC IS PROHIBITED.				

Items to Pay Attention to:

- Part is formed and assembled per drawings
- Make sure part is NOT sanded
- Metal finished radii are free from holes or pits
- Metal finished radii are consistent
- Edges are smoothed
- Part is free of jagged edges
- All tooling marks have been removed
- Part is free of sharpie marks
- Drop outs are clear of all cut outs
- Part is free of weld spatter
- Part is free of scratches and gouges
- Part has been wiped down with brake kleen
- All components of the assembly have been included

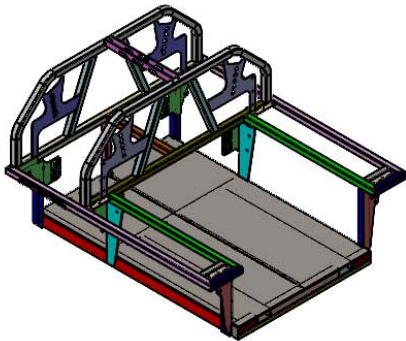

UNLESS OTHERWISE SPECIFIED:		NAME	DATE	 Nemesis Industries, Inc 33990 CR-27 T: 303-974-2440 Kiowa, Co 80117 F: 303-953-5212 www.nem-ind.com			
DIMENSIONS ARE IN INCHES	DRAWN	MRH	9/9/2025				
TOLERANCES:	APPROVED						
ANGULAR: $\pm .05^\circ$	Drawing Status	Development					
TWO PLACE DECIMAL $\pm .030$	COMMENTS:			Part Number	REV		
THREE PLACE DECIMAL $\pm .010$	Quality Control			99910-91	1		
DO NOT SCALE DRAWING				SHEET 19 OF 19			
MATERIAL: Steel				<p style="text-align: center;">PROPRIETARY AND CONFIDENTIAL</p> THE INFORMATION CONTAINED IN THIS DRAWING IS THE SOLE PROPERTY OF NEMESIS INDUSTRIES, INC. ANY REPRODUCTION IN PART OR AS A WHOLE WITHOUT THE WRITTEN PERMISSION OF NEMESIS INDUSTRIES, INC IS PROHIBITED.			
THICKNESS:							
FINISH:							